

# Varnostni ventil



Izvedba: kotna  
 Tlak: 0,5 – 25 bar (odvisno od izvedbe)  
 Temp. medija: do +225°C (odvisno od izvedbe)  
 Medij: zrak, para, plini, tekočina  
 Material: medenina



## TIP 851 P

Tesnilo iz perburana – za tlačne posode po AD-A2, za zrak, plin in paro do + 140°C.  
 Nastavitve: 0,5 – 16 bar.

## TIP 851 T

Tesnilo iz teflona – za tlačne posode po AD-A2 in parne kotle po TRD421 za paro zrak in pline do + 225°C. Možna izvedba do 3 bar in + 140°C z EPDM tesnilom.  
 Nastavitve: 0,5 – 25 bar.

## TIP 851 Bg

EPDM tesnilo. Za vnetljive in strupene pline, paro in zrak do + 140°C.  
 Nastavitve: 0,5 – 25 bar.

Priključek R	1/2"	3/4"	1"	1 1/4"
mm R1	1"	1 1/4"	1 1/2"	2"
mm L	34	41	48	64
mm H	75	140	175	240
mm h	26	36	43	53
mm SW1	27	34	41	52
mm SW2	41	50	58	70
mm do 851 P/T	15	15	20	28
mm do 851 bG	15,8	18	23	30
Območje nastavitve (bar)				
851 P	0.5-16	0.5-16	0.5-16	0.5-16
851T	0.5-25	0.5-25	0.5-25	0.5-25
Para / plin				
851 bG	0.5-25	0.5-25	0.5-25	0.5-25
Vnetljivi in strupeni plini/para				

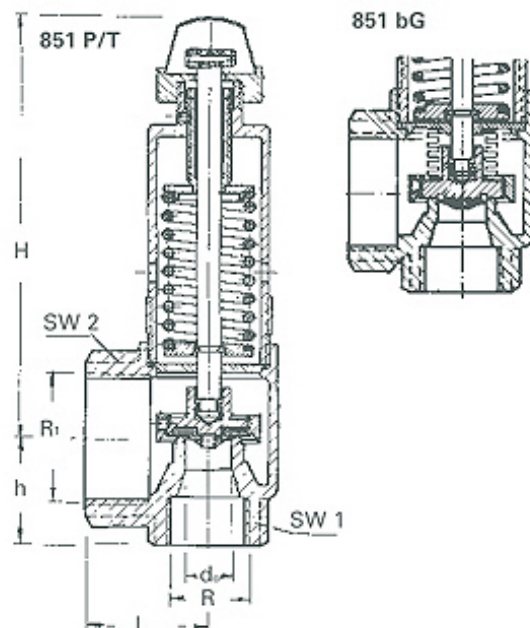

Pretok za 851 P/T

bar	0.5	1	2	4	6	8	10	12	14	16
1/2"	40	54	98	160	225	285	346	407	468	525
3/4"	76	102	175	285	400	505	615	720	880	935
1"	136	182	310	510	715	900	1095	1290	1480	1660
1 1/4"	268	356	610	990	1395	1765	2150	2520	2860	3260
kg/h pare										
1/2"	50	81	122	204	286	368	450	530	612	694
3/4"	96	128	220	360	510	650	800	940	1090	1230
1"	171	228	390	645	900	1160	1420	1680	1935	2190
1 1/4"	335	447	755	1260	1760	2270	2770	3275	3780	4280
Nm <sup>3</sup> /h zraka										

Pretok za 851 bG

bar	0,5	1	2	4	6	8	10	12	14	16	18	20	22	24
1/2"	41	56	84	175	240	310	380	434	499	564	629	694	759	824
3/4"	94	129	190	410	570	730	900	1023	1178	1331	1485	1638	1792	1946
1"	150	200	300	630	870	1120	1370	1559	1794	2028	2262	2495	2730	2846
1 1/4"	260	350	520	1100	1500	1950	2350	2706	3114	3520	3926	4331	4738	5145
kg/h pare														
1/2"	50	67	109	213	298	384	470	572	660	749	837	925	1013	1100
3/4"	116	155	232	505	707	909	1110	1350	1558	1766	1974	2182	2390	2597
1"	181	242	362	769	1076	1384	1691	2058	2375	2691	3008	3325	3641	3958
1 1/4"	308	410	616	1306	1829	2352	2874	3572	4122	4671	5220	5770	6320	6869
Nm <sup>3</sup> /h zraka														